

RETAINING RINGS

Material:
Spring steel

Hardness:
48÷52 HRC 485÷545 HV

SURFACE FINISHES
Phosphated and oiled
Blackened and oiled
Manufacturer's choice

Example of designation:
ring type **HM 15 IMPILATI**

non in tensione
unstressed

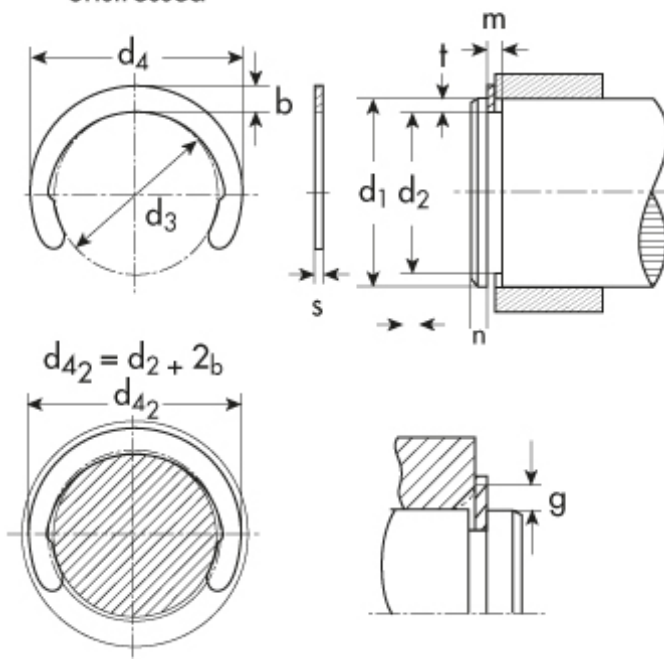

crescent rings
type **HM** - for
shafts -stacked



d₁=shaft diameter
d₂=groove diameter
d₃=inner diameter in the unstressed state
d₄=external diameter in the unstressed state
s=thickness

d1	Description	Price euro /100	% Price Change		Package
			1	2	
14.00	HM 14 IMPILATI	9,00 •	-	-	2000

RING		GROOVE		SUPPLEMENTARY DATA	
d₁	14.00	d₂	12.7	n	2.0
s	1.00	tole d₂	-0.11	FN (kN)	2.20
tole s	-0.06	m	1.10	FR (kN)	5.00
d₃	12.30	t	0.65	g	1.00
tole d₃	+0.18 -0.18			FRg (kN)	2.00
b ~	2.00			d₄₂	16.7
d₄	16.30			n_{abl.} x1000 (giri/min)	27
weight kg/1000	0.400			plier	GRH 14

Technical informations are indicative and can be updated.

Copyright Gandini Fasteners S.r.l. All rights reserved. No part of this web site may be reproduced in any form without express permission.

GANDINI FASTENERS SRL viale Pier Paolo Pasolini, 83 - 20099 Sesto S.Giovanni Milano Italy
Tel. +39 02 241 047 250 Fax +39 02 241 047 74

Production and distribution
of fasteners, fixing elements
and mechanical parts
machining

GANDINI FASTENERS SRL
viale Pier Paolo Pasolini, 83
Sesto San Giovanni Mi - Italy

Sales department
250@gandini.it
tel +39 02 241 047 250

Administration
350@gandini.it
tel +39 02 241 047 350