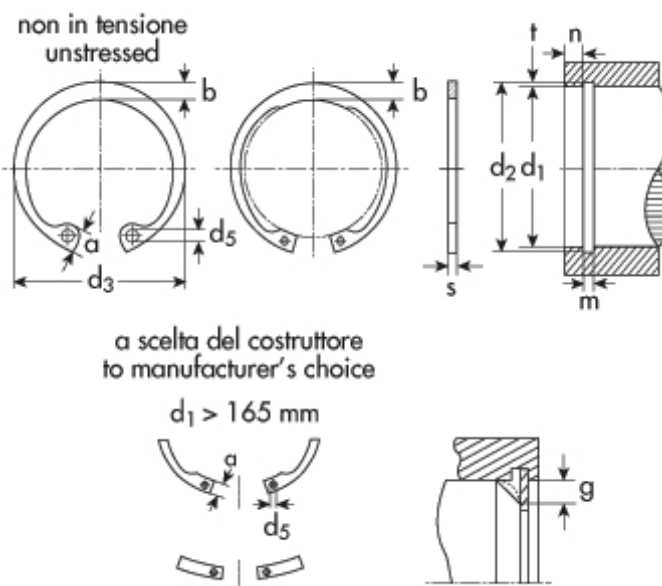

**RETAINING RINGS**
**Material:** Spring steel

**Hardness:**
**SURFACE FINISHES**  
 Phosphated and oiled  
 Blackened and oiled  
 Manufacturer's choice

**Example of designation:**  
 ring type JM 20 IMPILATI

 DIN 472  
 UNI 3654-7437  
 Type JM - for bores-stacked

$d_1$ =bore diameter  
 $d_2$ =groove diameter  
 $d_3$ =ring diameter in the unstressed state  
 $s$ =thickness

d1	Description	Price euro /100	% Price Change		Package
			1	2	
29.00	JM 29 impilati	on demand	-	-	-

RING		GROOVE		SUPPLEMENTARY DATA	
$d_1$	29.00	$d_2$	30.4	n	2.1
s	1.20	tole $d_2$	0.25	FN (kN)	10.90
tole s	-0.06	m	1.30	FR (kN)	13.6
$d_3$	31.1	t	0.70	g	1.0
tole $d_3$	+0.50 -0.25			FRg (kN)	4.6
a max	4.8			AN (mm <sup>2</sup> )	65.3
b ~	3.0			K (kN.mm)	26.8
$d_5$ min	2.0			plier	ZGJ 2
weight kg/1000	1.880				

Technical informations are indicative and can be updated.

Copyright Gandini Fasteners S.r.l. All rights reserved. No part of this web site may be reproduced in any form without express permission.

**GANDINI FASTENERS SRL** viale Pier Paolo Pasolini, 83 - 20099 Sesto S.Giovanni Milano Italy  
 Tel. +39 02 241 047 250 Fax +39 02 241 047 74

 Production and distribution  
 of fasteners, fixing elements  
 and mechanical parts  
 machining

**GANDINI FASTENERS SRL**  
 viale Pier Paolo Pasolini, 83  
 Sesto San Giovanni Mi - Italy

**Sales department**  
 250@gandini.it  
 tel +39 02 241 047 250

**Administration**  
 350@gandini.it  
 tel +39 02 241 047 350